

RECOM-S[®]

Recombiner: Stationary / Vented Batteries



RECOM Technology

The **RECOM-S** system is engineered specifically for vented nickel-cadmium, nickel-iron, and lead-acid stationary battery cells, offering a remarkable solution to prevent water loss and reduce maintenance. The advanced design recombines the hydrogen and oxygen gases into water before these gases escape the cell, resulting in a nearly maintenance-free battery.



No gassing...



No watering...



SAVE MONEY!!

Low Maintenance + SAFETY + Cost Saving

RECOM's 99%+ efficiency in water retention means that cells may only require watering every five years, or even less frequently, depending on the applications. This innovation provides flooded batteries with virtually zero watering maintenance and reduces the time technicians are exposed to the battery hazards.



TECHNICAL SPECIFICATIONS

Gas Recombination Rate	114 +/- 10 cc/min H2 & O2
Max/Min Operating Temp	90°C (194°F) / 0°C (32°F)
Max Unit Material Temp	274°C (525°F)
Battery Capacity Rating	0-4000 Ah
Application	Stationary Flooded/Vented
Diameter	38mm (1.50")
Height Above Vent	31mm (1.23")

Features

- Over 99% recombination, no watering needed!
- Designed to fit all U.S. and European batteries
- No valve design eliminates any cell pressurization
- Every component in the RECOM-S can withstand temperatures up to 525°F
- Reduces explosive Hydrogen gas for lower ventilation costs
- Life expectancy of 20+ years (5-year warranty)
- The lowest profile Recombiner on the market
- Patent Pending Technology

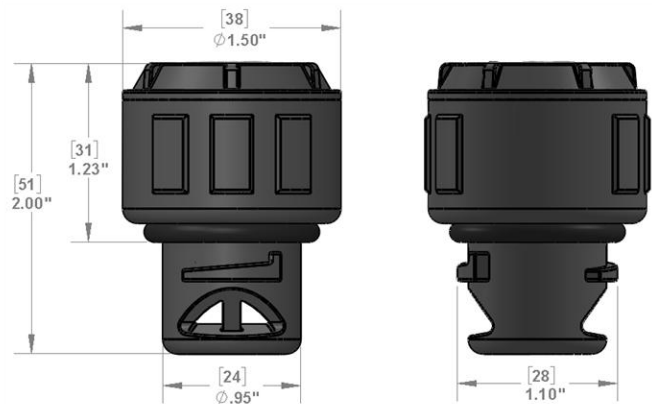

FOR PRODUCT DATA, USER GUIDES, AND FURTHER INFORMATION, PLEASE VISIT: [HTTPS://WWW.BATTERYINNOVATIONSLLC.COM](https://www.batteryinnovationsllc.com)



Battery Innovations LLC

Product Design and Consulting

www.batteryinnovationsllc.com

Battery Innovations LLC
500 Office Center Drive, Suite 400
Fort Washington, PA 19034 USA
P: 267-625-4252
E: sales@batteryinnovationsllc.com