



# CATVent<sup>®</sup>

• F L O O D E D / V E N T E D •



Model no. CTL-200

Battery Technology Flooded / Vented (NiCad / Lead Acid)

Usage Near zero gassing vent for 2V cells up to 4000Ah<sup>1</sup>

## NEAR ZERO WATER LOSS, NEAR ZERO GASSING, HYGROSCOPIC CATALYZED RECOMBINATION VENTS FOR FLOODED / VENTED BATTERIES



**NO GAS<sup>2</sup>**



**NO WATER LOSS<sup>2</sup>**



**NO MAINTENANCE<sup>3</sup>**

The Philadelphia Scientific CTL-200 catalytic recombination vent is specially designed for flooded/vented cells in stationary battery applications.

The CTL-200 efficiently recombines Hydrogen and Oxygen back into water before it leaves the cell. The result is that the battery becomes virtually maintenance free while hydrogen gas emissions are all but eliminated.

The CTL-200 features a low pressure, 2-way vent system, which seals the cell allowing the gasses time to be recombined efficiently while providing overpressure and vacuum protection. This turns a standard flooded/vented cell into a (flooded/vented) valve regulated cell. (Also available without the 2-way pressure regulating valve as CTL-210)

The principle of hygroscopic absorption is used which eliminates the need for large external condensing surfaces. This allows the CTL-200 to be efficient while maintaining a low profile.

Safety is important so the CTL-200 is designed to be intrinsically safe in events of unintended overcharge. A combination of a self-limiting catalytic core and ultra-high temperature materials ensures the catalyst remains safe in all conditions.

- Over 99% effective in recombining gases back into water vapor. (93% as CTL-210).
- Utilizes the hygroscopic environment of the cell, not condensation.
- Capable of neutralizing hydrogen sulfide, stibine, arsine and amines.
- Catalyst core designed to limit the rate of recombination which controls the unit temperature to prevent damage.
- Reduction in explosive gas release reduces the ventilation costs.
- Eliminates the risk of adding contaminated water to the cells.
- Testing has shown the capability to safely withstand extended periods of 50 amps of overcurrent gas generation without degradation.<sup>4</sup>





## TECHNICAL SPECIFICATIONS - CTL-200/210

Recombination Rating	65.2 +/- 5.0 cc/min H <sub>2</sub> & O <sub>2</sub>
Max Internal Temperature	260°C (500°F)
Max External Temperature	93°C (200°F)
Valve Opening Pressure (CLT-200) Only	10 mbar
Body Materials	Non Hygroscopic, High-Impact, High-Temperature Polymer
Dimensions	
Diameter	38.1mm (1.5")
Height Above Vent	50.8mm (2.0")

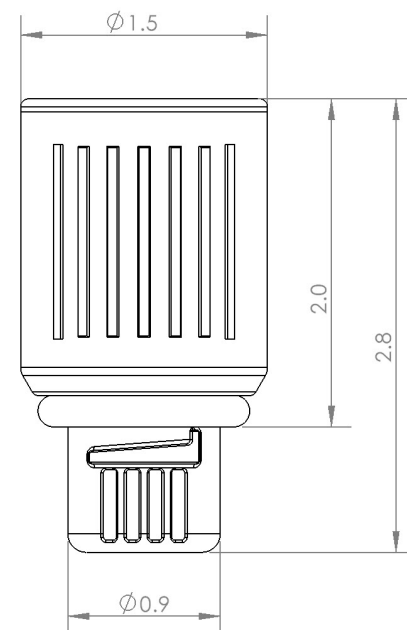

\*1 Dependant on alloy, temperature and float voltage.

\*2 Based on observations over a 12 month period.

\*3 Due to watering requirements.

\*4 Degradation is defined as physical failure of the recombination vent



**FOR PRODUCT SPECIFICATIONS, USER GUIDES AND FURTHER INFORMATION PLEASE VISIT:**

[HTTPS://WWW.PHLSCI.COM/PRODUCT-LINES/MICROCAT-CATALYST/CATVENT-CTL-200-US/](https://www.phlsci.com/product-lines/microcat-catalyst/catvent-ctl-200-us/)

DOC0645 © by Philadelphia Scientific. All rights reserved. Philadelphia Scientific, the PS logo are registered trademarks of Philadelphia Scientific. R12-271025



**WWW.PHLSCI.COM**

Philadelphia Scientific LLC  
P: +1 (215) 616 0390  
E: info@phlsci.com

Philadelphia Scientific EMEA  
P: +44 (0) 1204 467777  
E: info@phlsci.co.uk

Philadelphia Scientific ASIA PACIFIC  
P: +61 (2) 8004 2447  
E: info@phlsci.com.au

